

# G4XTREME

Oil Enhancement



# G4X ENHANCES YOUR CURRENT OIL

Conventional motor oils have a certain limit in which they can no longer provide lubrication because the friction is so great. Once **G4X** has been added the failing point of these oils has been shown to increase more than 500%. This causes a tremendous reduction in friction. This will equate to less metal wear, better fuel economy and capturing the wasted Horse Power that is lost due to friction.

**MORE TORQUE**

**MORE HORSEPOWER**

**MORE MILES PER GALLON**

**LOWER OPERATING TEMPERATURE**

# WHAT IS G4X

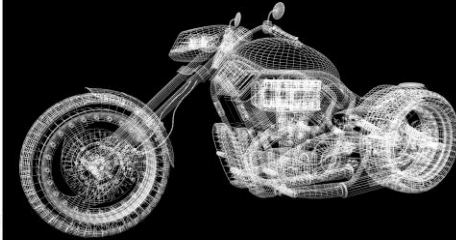
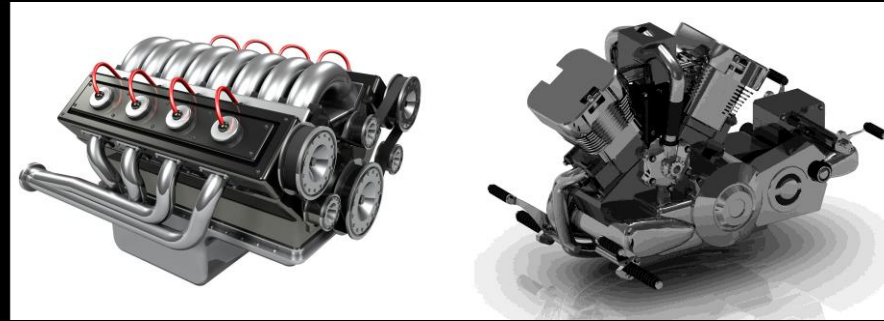
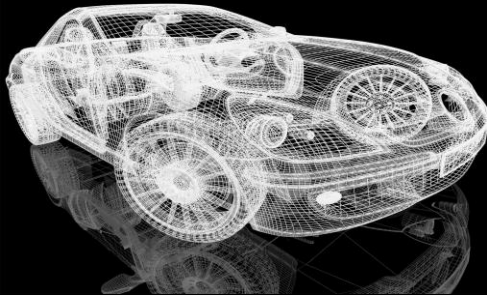

**G4X** is a unique supplement that enhances any engines overall performance and efficiency. **G4X** will bond to all the metal surfaces and become a boundary lubricant; the oil will do its job better while reducing friction and metal wear. This protection will lead to longer engine life, reduced maintenance and improvement in fuel economy.

# COMPATIBILITY

The properties of **G4X** allow it to be used with all blends and types of recommended automotive oils. **G4X** has the same viscosity ranges and tolerances of recommended automotive oils. **G4X** is compatible for all engines and has dramatic reduction in operating temperatures while extending the life of engines, differentials, manual transmissions and power steering.

TEST	METHOD	RESULTS
SAE GRADE	SAE J300	20w-30
GRAVITY SP @ 60°F	ASTM D-287	0.9986
VISCOSITY @ 40°C	ASTM D-445	54.63
VISCOSITY @ 100°C	ASTM D-445	9.57
VISCOSITY INDEX	ASTM D-2270	161
FLASH POINT, °C	ASTM D-93	374
POUR POINT, °C	ASTM D-97	-22

# WHAT G4X IS **NOT**

G4X does not contain any harmful additives such as:

- Teflon
- Silicon
- Zinc
- Molys
- Graphite
- or any other solids



# PRODUCT BENEFITS

G4X PROVIDES 500 -1,000% IMPROVEMENT OVER THE INDUSTRY STANDARD MOTOR OIL FAILURE POINT

## **METAL BEARING BEFORE AND AFTER TREATMENT**

*AS SEEN UNDER A MICROSCOPE*

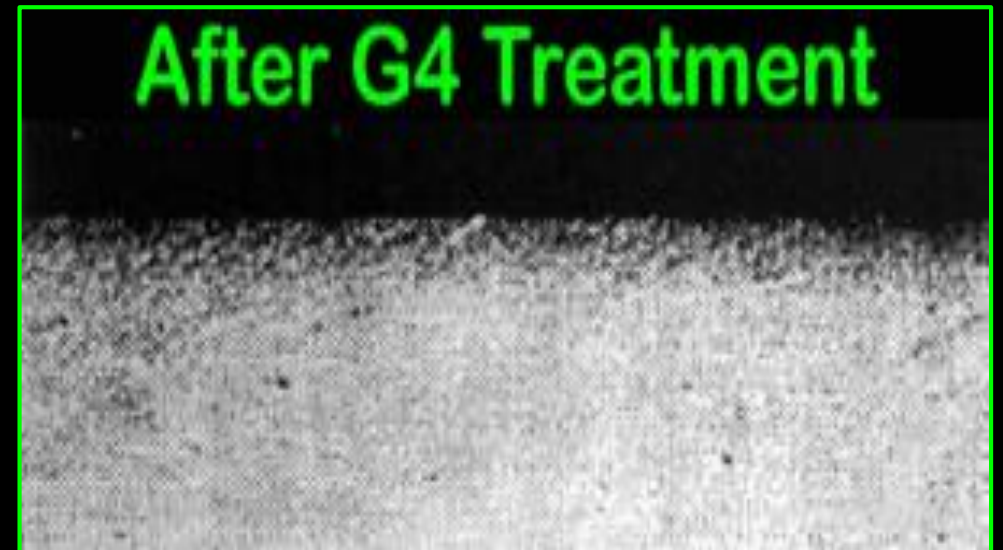
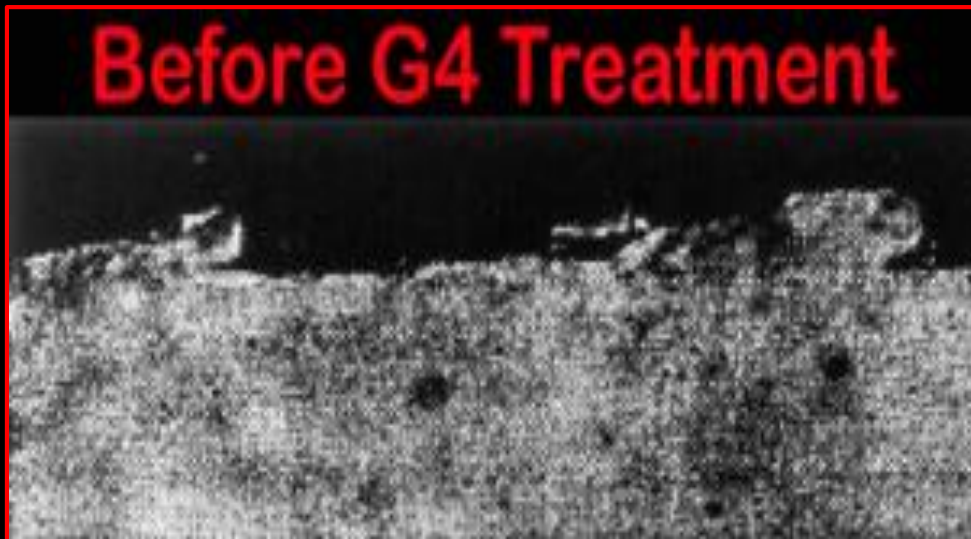

# PRODUCT BENEFITS

## **DRY STARTS**

Significant engine wear comes from the initial dry start after an engine has been shut off for an extended period of time and the oil is no longer protecting the metal surfaces. Once G4X bonds to the metal, it remains there providing constant protection.

## **REJUVENATED SEALS**

Not only does G4X protect the internal metal surfaces of your engine, but it also rejuvenates seal life, protecting the motor from overheating in the event of a cooling failure.

# PRODUCT BENEFITS

## **MORE MILES PER GALLON**

G4X PROVIDES 500-1,000% IMPROVEMENT OVER THE INDUSTRY STANDARD MOTOR OIL FAILURE POINT. THIS IMPROVEMENT LEADS TO LESS FRICTION, WHICH IN TURN REQUIRES LESS FUEL TO DO THE SAME AMOUNT OF WORK. G4X WILL PROVIDE AN ESTIMATED 8-10% IMPROVEMENT IN YOUR MILES PER GALLON. RESULTING IN LESS TRIPS TO THE GAS STATION.

## **PAYS FOR ITSELF**

THE MORE YOU DRIVE THE MORE YOU SAVE BY USING G4X. THE FUEL SAVINGS SHOULD BE SEEN WITHIN THE FIRST FILL UP AND THE MAINTENANCE REDUCTION WILL CONTINUE TO BE SEEN OVER THE LIFE OF THE ENGINE. IT'S NOT UNCOMMON FOR G4X TO PAY FOR ITSELF IN JUST A FEW FILL UPS.



# FLEET DATA- MPG INCREASE



Harmon Oil - Local Delivery Fleet

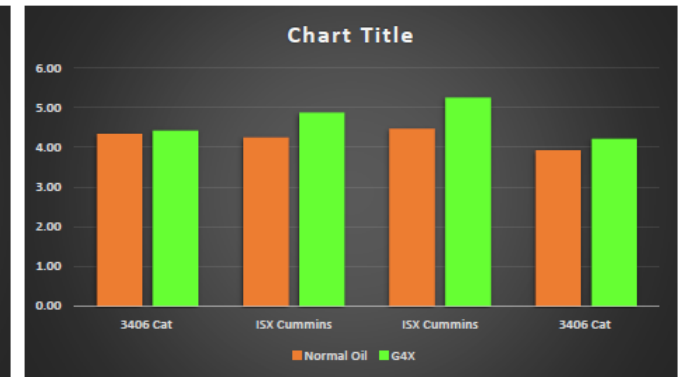
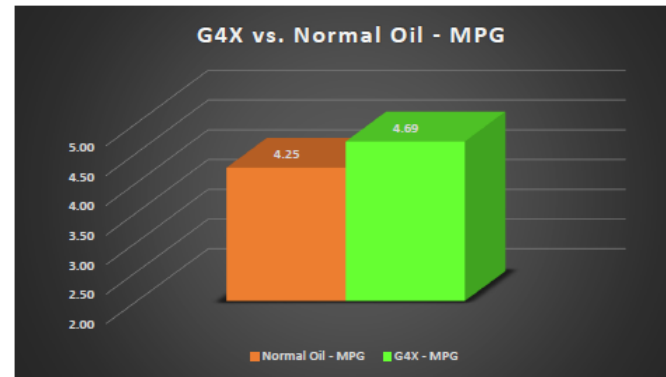

6 Month Evaluation Period				
LD-Truck#	Engine	Normal Oil - MPG	G4X - MPG	% Change
Truck #24	3406 Cat	4.34	4.42	1.84%
Truck #31	ISX Cummins	4.25	4.87	14.59%
Truck #35	ISX Cummins	4.47	5.25	17.45%
Truck #32	3406 Cat	3.93	4.21	7.12%
<b>Totals</b>		<b>4.25</b>	<b>4.69</b>	<b>10.36%</b>

Fleet Avg. MPG Results		
Normal Oil	With G4X	% Change-Results
<b>4.25</b>	<b>4.69</b>	<b>10.36%</b>

# DYNO TESTING – FUEL REDUCTION

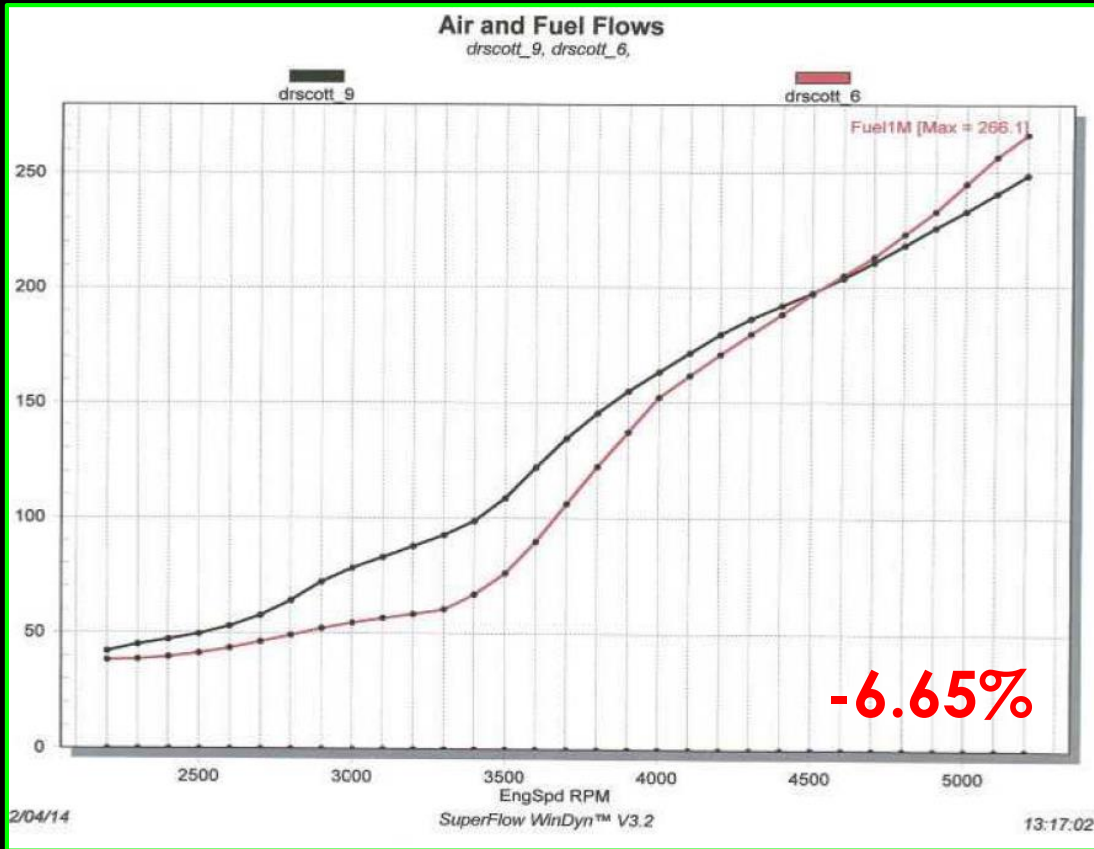

Dyno Test Results			
Make:	Chevy	Model:	Big Block
Engine:	V8 w/ Super Charger	Tested By:	Tyler Crockett Marine Engines
Before:	266.1 Fuel Consumption	After:	248.4 Fuel Consumption

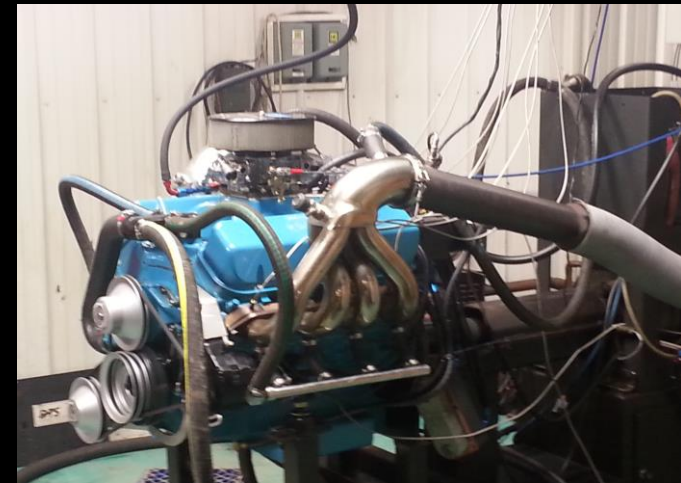

# HORSEPOWER AND TORQUE

**G4X** has been shown to have increases up to 30 horse when the complete drive train is treated. Typically 5 – 10 horsepower can be achieved with an oil change.

This horsepower can be attributed to the reduction in friction and the cool motor temperatures. The horsepower gain is about the equivalent of a port and polish, with 90% less cost.

With the extreme environment that a racing motor will endure, the added protection of **G4X** will enhance most of all motor operations. Not only will **G4X** protect the metal surfaces internally, but it will rejuvenate seal life and assist in protecting the motor from overheating should failures in cooling occur.

# DYNO TESTING – HORSEPOWER

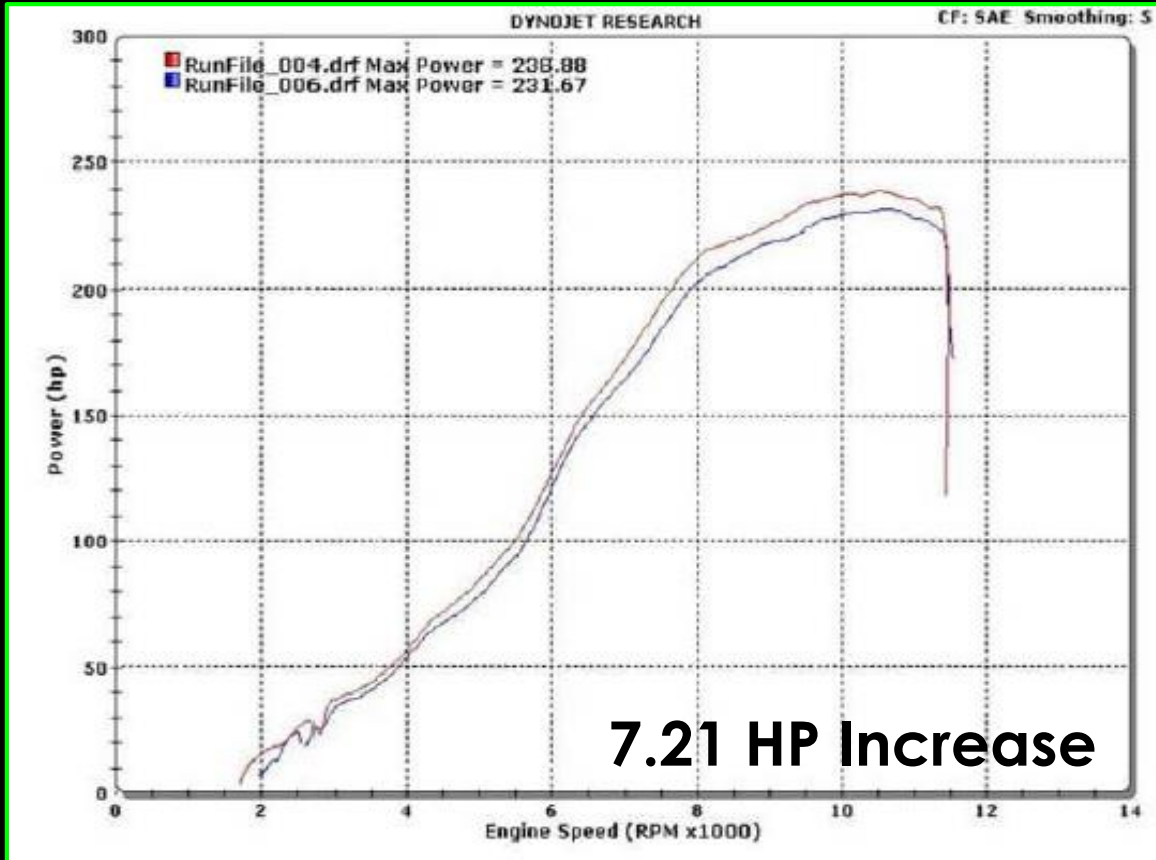

Dyno Test Results			
Make:	Suzuki	Model:	Hayabusa
Engine:	1300cc	Tested By:	Performance Cycle and Dyno
Before:	231.67 hp	After:	238.88 hp



# WHAT THE PROFESSIONALS ARE SAYING ABOUT G4X

OPA World Champion &  
Engine Builder



"I tested G4X an now the Special Sauce goes in my engines"

Tyler Crockett

AMA Champion &  
Hall of Fame Racer



"Where was this product when i was racing ?"

Jay Springsteen

Owner-Tuner-Engine  
Builder for PCD



"All I can is WoW, Your product works PERIOD!"

Donnie Stear

# WHAT THE PROFESSIONALS ARE SAYING ABOUT G4X



# INSTALLATION

## EQUIPMENT ASSESSMENT

Do not begin installation until the engine is operating at proper manufacturer specifications. All service lights and emissions should be recorded before installation. Inspection of the oil dipstick showing the oil level will be necessary. Ensure there is no chance of rain for the installation period if outdoors. The engine must not be running to install. Installer must follow all engine manufacturer's instructions for oil top off.

## INSTALLATION

Only a qualified licensed automotive technician should do the installation. Determine the proper amount of G4X to be installed into the units. This is equal **10% of the engine's oil capacity**. Pour the G4X into the oil filler port as specified by the engine's manufacturer. Once the desired amount of G4X is installed, clean the area and ensure that any spills are contained and disposed of by the specifications of local governance.

# STORAGE AND HANDLING

- Store products in manufacturer's unopened packaging until ready for installation.
- Store and dispose of materials in accordance with requirements of local authorities having jurisdiction.
- Keep all Products in room temperature environment with low humidity.





# FREQUENTLY ASKED QUESTIONS

## WILL G4X VOID MY WARRANTY?

No, G4X will not void the warranty. G4X is blended to meet all manufacturer's specifications. All the physical properties including the viscosity stay the same.

## IS G4X COMPATIBLE WITH SYNTHETIC OR NON SYNTHETIC OILS?

The properties of G4X allow it to be used with all blends and types of recommended automotive oils.

## HOW OFTEN SHOULD I USE G4X?

We recommend that G4X be used at each oil change but can last until the third change.

# WHO NEEDS G4X ?



# G4X APPLICATIONS

- Roller Coasters
- Turbines
- Tractors
- Combines
- Drilling Equipment
- Locomotives
- Freighters
- Tow Trucks
- Air Compressors
- Excavators
- Draglines
- Drills
- Roof Bolters
- Continuous Miners
- Longwall Miners
- Rock Duster
- Asphalt Paver
- Semi-Trucks
- Cruise Ships
- Yachts
- Barges
- Tugboats
- Speed Boats
- Water Taxi
- Ferries
- Jet Ski's
- Generators
- Compressors
- Lawn Mowers
- Snowmobile
- Motorcycles
- Cars
- Truck
- Buses
- RV's
- Gear Boxes

***WHEN POWER MATTERS***



***G4*** Xtreme

***Oil Enhancement***

***www.WhenPowerMatters.com***